



## Caracteristici Principale

Gama de produse	Altivar Process ATV900
Tip produs sau componenta	Variator de viteza
Domeniul de aplicare al aparatului	Industrial application
Nume scurt al dispozitivului	ATV930
Varianta	Standard version
Destinație produs	Motoare asincrone Motoare sincrone
Mod de montare	Wall mount
Filtru EMC	Integrat conformitate cu EN/IEC 61800-3 category C2 cu 50 m motor cable maxi Integrat conformitate cu EN/IEC 61800-3 category C3 cu 150 m motor cable maxi
Grad de protecție IP	IP21 conformitate cu IEC 61800-5-1 IP21 conformitate cu SR EN 60529
Degree of protection	UL type 1 conformitate cu UL 508C
Tip de racire	Convecție forțată
Frecvența de alimentare	50...60 Hz (+/- 5 %)
Network number of phases	3 phases
[Us] tensiune nominală de alimentare	380...480 V (- 15...10 %)
Putere motor kW	22 kW (normal duty) 18.5 kW (heavy duty)
Putere motor hp	30 hp (normal duty) 25 hp (heavy duty)
Curent de linie	39.6 A at 380 V (normal duty) 34.4 A at 480 V (normal duty) 34.1 A at 380 V (heavy duty) 29.9 A at 480 V (heavy duty)
Curent de scurtcircuit prezumat I <sub>sc</sub>	50 kA
Putere aparentă	28.6 kVA at 480 V (normal duty) 24.9 kVA at 480 V (heavy duty)
Curent la ieșire continuu	46.3 A at 4 kHz (normal duty) 39.2 A at 4 kHz (heavy duty)
Curent tranzitoriu maxim	58.8 A during 60 s (heavy duty) 55.6 A during 60 s (normal duty)
Profil de control al motorului asincron	Constant torque standard Variable torque standard Optimized torque mode
Profil de control al motorului sincron	Permanent magnet motor
Frecvența de ieșire a convertizorului	0.1...500 Hz
Frecvența de comutare nominală	4 kHz
Frecvența de comutare	2...16 kHz reglabil 4...16 kHz cu factor de declasare
Safety function	STO (safe torque off) SIL 3
Logica de intrare discretă	16 preset speeds
Protocol port de comunicare	Serial Modbus Modbus TCP Ethernet IP
Card opțional	Slot A: communication module pentru Profibus DP V1

Informațiile oferite în această documentație conțin descrieri generale și caracteristici tehnice legate de produsele prezentate. Această documentație nu este un substitut pentru și nu trebuie folosită pentru a determina compatibilitatea și fiabilitatea acestor produse în aplicațiile specifice ale clienților. Este de datoria utilizatorului sau a integratorului să efectueze analiza completă de risc, evaluarea și testarea produselor pentru utilizarea în aplicațiile specifice. Schneider Electric Industries SAS și filialele sale nu pot fi răspunzătoare pentru întrebările conținute în această documentație.

Slot A: communication module pentru Profinet  
 Slot A: communication module pentru DeviceNet  
 Slot A: communication module pentru rețea  
 CANopen RJ45  
 Slot A: communication module pentru CANopen  
 SUB-D 9  
 Slot A: communication module pentru CANopen  
 screw terminals  
 Slot A: communication module pentru EtherCAT  
 Slot A/slot B/slot C : digital and analog I/O  
 extension module  
 Slot A/slot B/slot C : output relay extension module  
 Slot B : 5/12 V digital encoder interface module  
 Slot B : analog encoder interface module  
 Slot B : resolver encoder interface module

## Complementare

Tensiune de iesire	<= tensiunea de alimentare
Compensare alunecare motor	Reglabil Automat indiferent de sarcina Poate fi suprimat Not available in permanent magnet motor law
Rampe de accelerare si decelerare	Reglabil liniar separat, de la 0,01 la 9000 s S, U sau personalizat
Franare sau imobil	Cu injectie c.c.
Tip de protectie	Motor : thermal protection Motor : safe torque off Motor : motor phase break Drive : thermal protection Drive : safe torque off Drive : overheating Drive : overcurrent between output phases and earth Drive : overload of output voltage Drive : short-circuit protection Drive : motor phase break Drive : overvoltages on the DC bus Drive : line supply overvoltage Drive : line supply undervoltage Drive : line supply phase loss Drive : overspeed Drive : break on the control circuit
Rezoluția frecvenței	Display unit : 0.1 Hz Analog input : 0.012/50 Hz
Conexiune electrica	Motor, screw terminal : 16 mm <sup>2</sup> (AWG 6) Line side, screw terminal : 10...16 mm <sup>2</sup> (AWG 8...AWG 6) Control, screw terminal : 0.5...1.5 mm <sup>2</sup> (AWG 20...AWG 16) DC bus, screw terminal : 10...16 mm <sup>2</sup> (AWG 8...AWG 6)
Tipul conectorului	2 RJ45 (on the control block) pentru Ethernet IP/Modbus TCP 1 RJ45 (on the control block) pentru serial Modbus
Interfata fizica	RS 485 cu 2 fire pentru serial Modbus
Cadru de transmisie	RTU pentru serial Modbus
Rata de transmisie	10/100 Mbit/s pentru Ethernet IP/Modbus TCP 4.8, 9.6, 19.2, 38.4 kbit/s for serial Modbus
Exchange mode	Half duplex, full duplex, autonegotiation pentru Ethernet IP/Modbus TCP
Format data	8 bits, configurable odd, even or no parity pentru serial Modbus
Tip de polarizare	Fara impedanta pentru serial Modbus
Număr de adrese	1...247 pentru serial Modbus
Metoda de acces	Slave pentru Modbus TCP
Alimentare	External supply for digital inputs: 24 V c.c. (19...30 V) current <= 1.25 mA (protecție la suprasarcină și scurtcircuit) Sursă internă pentru potențiometrul de referință (1 la 10 kOhm): 10.5 V c.c. +/- 5 % current <= 10 mA (protecție la suprasarcină și scurtcircuit) Internal supply for digital inputs and STO: 24 V c.c. (21...27 V) current <= 200 mA (protecție la suprasarcină și scurtcircuit)
Semnalizare locala	3 LED(s) mono/dual colour for local diagnostic
Lățime	211 mm
Înălțime	545.9 mm
Adâncime	235 mm

Greutate produs	14.3 kg
Numărul intrării analogice	3
Tip de intrare analogica	Software-configurable voltage AI1, AI2, AI3 : 0...10 V DC impedance 30 kOhm, resolution 12 bits Software-configurable current AI1, AI2, AI3 : 0...20 mA impedance 250 Ohm, resolution 12 bits
Număr intrare discretă	10
Tip de intrare discreta	Programmable DI1...DI8 : 24 V DC ( $\leq 30$ V) impedance 3.5 kOhm Programmable as pulse input DI7, DI8 0...30 kHz : 24 V DC ( $\leq 30$ V) Safe torque off STOA, STOB : 24 V DC ( $\leq 30$ V) impedance $> 2.2$ kOhm
Compatibilitate intrare	Intrare directă STOA, STOB: nivel 1 PLC conformitate cu EN/IEC 61131-2 Intrare directă DI1...DI8: nivel 1 PLC conformitate cu EN/IEC 61131-2 Pulse input DI7, DI8: nivel 1 PLC conformitate cu IEC 65A-68
Logica de intrare discreta	STOA, STOB, positive logic (source) : $< 5$ V (state 0) $> 11$ V (state 1) DI1...DI8, positive logic (source) : $< 5$ V (state 0) $> 11$ V (state 1) DI1...DI8, negative logic (sink) : $> 16$ V (state 0) $< 10$ V (state 1) DI7, DI8, positive logic (source) : $< 0.6$ V (state 0) $> 2.5$ V (state 1)
Numărul ieșirii analogice	2
Tip ieșire analogică	Software-configurable voltage AQ1, AQ2 : 0...10 V DC impedance 470 Ohm, resolution 10 bits Software-configurable current AQ1, AQ2 : 0...20 mA impedance 500 Ohm, resolution 10 bits
Număr ieșire discretă	2
Tip de iesire discreta	Logic output DQ+ : 0...1 kHz ( $\leq 30$ V) DC, $< 100$ mA Programmable as pulse output DQ+ : 0...30 kHz ( $\leq 30$ V) DC, $< 20$ mA Logic output DQ- : 0...1 kHz ( $\leq 30$ V) DC, $< 100$ mA
Perioada de eșantionare	Discrete input DI1...DI8 : 2 ms (+/- 0.5 ms) Pulse input DI7, DI8 : 5 ms (+/- 1 ms) Analog input AI1, AI2, AI3 : 1 ms (+/- 1 ms) Analog output AQ1, AQ2 : 5 ms (+/- 1 ms)
Precizie	Analog input AI1, AI2, AI3 : +/- 0.6 % for a temperature variation 60 °C Analog output AQ1, AQ2 : +/- 1 % for a temperature variation 60 °C
Eroare de liniaritate	Intrare analogică AI1, AI2, AI3: +/- 0.15 % din valoarea maximă Analog output AQ1, AQ2 : +/- 0.2 %
Relay output number	3
Relay output type	Configurable relay logic R1 : fault relay NO/NC electrical durability 100000 cycles Configurable relay logic R2 : sequence relay NO electrical durability 1000000 cycles Configurable relay logic R3 : sequence relay NO electrical durability 1000000 cycles
Timp de reîmprospătare	Relay output R1, R2, R3: 5 ms (+/- 0.5 ms)
Curentul minim de comutare	Relay output R1, R2, R3: 5 mA la 24 V c.c.
Curent maxim de comutație	Relay output R1 on inductive load (cos phi = 0.4 and L/R = 7 ms) : 2 A at 250 V AC Relay output R1 on inductive load (cos phi = 0.4 and L/R = 7 ms) : 2 A at 30 V DC Relay output R2, R3 on inductive load (cos phi = 0.4 and L/R = 7 ms) : 2 A at 250 V AC Relay output R2, R3 on inductive load (cos phi = 0.4 and L/R = 7 ms) : 2 A at 30 V DC Relay output R1 pornit rezistiv sarcina (cos phi = 1) : 3 A la 250 V c.a. Relay output R1 pornit rezistiv sarcina (cos phi = 1) : 3 A la 30 V c.c. Relay output R2, R3 pornit rezistiv sarcina (cos phi = 1) : 5 A la 250 V c.a. Relay output R2, R3 pornit rezistiv sarcina (cos phi = 1) : 5 A la 30 V c.c.
Izolatie	Intre alimentare si bornele de control
Specific application	Process
IP degree of protection	IP21
Variable speed drive application selection	Food and beverage processing mixer Food and beverage processing conveyor Food and beverage processing shredder Hoisting process crane Marine thruster Marine winch Material working (wood, ceramic, stone, pvc, metal) press Material working (wood, ceramic, stone, pvc, metal) extruder Mining mineral and metal other application Oil and gas drilling rig Oil and gas progressive cavity pump Oil and gas rod pump Oil and gas swapping pump Oil and gas compressor for regasification Oil and gas separator Oil and gas other application Water and waste water separator

Motor power range AC-3	15...25 kW 380...440 V 3 faze 15...25 kW 480...500 V 3 faze
Motor starter type	Variable speed drive

## Mediu

rezistență de izolație	> 1 mOhm la 500 V c.c. pentru 1 minut la pământ
nivel de zgomot	59.5 dB conformitate cu 86/188/EEC
puterea disipată în W	68 W (convecție naturala) la 380 V switching frequency 4 kHz 505 W (convecție forțata) la 380 V switching frequency 4 kHz
volume of cooling air	215 m <sup>3</sup> /h
poziție de operare	Vertical +/- 10 grade
THDI	<= 48 % from 80...100 % of load conformitate cu IEC 61000-3-12
compatibilitate electromagnetice	1.2/50 μs - 8/20 μs test de imunitate la supratensiuni nivel 3 conformitate cu IEC 61000-4-5 Tranzienți rapizi/test de imunitate la impulsuri de ionizare nivel 4 conformitate cu IEC 61000-4-4 Test de imunitate la descărcări electrostatice nivel 3 conformitate cu IEC 61000-4-2 Test de imunitate la frecvență radio radiată nivel 3 conformitate cu IEC 61000-4-3 Test de imunitate la radiofrecvență condusă nivel 3 conformitate cu IEC 61000-4-6
grad de poluare	2 EN/IEC 61800-5-1
rezistența la vibrații	1 gn (f = 13...200 Hz) conformitate cu IEC 60068-2-6 1.5 mm peak to peak (f = 2...13 Hz) conforming to IEC 60068-2-6
rezistența la socuri	15 gn during 11 ms conforming to IEC 60068-2-27
umiditate relativă	5...95 % fără condensare conformitate cu IEC 60068-2-3
temperatura de utilizare	50...60 °C cu factor de declasare -15...50 °C without derating
temperatura de depozitare	-40...70 °C
altitudinea de funcționare	<= 1000 m fără declasare 1000...4800 m with current derating 1 % per 100 m
caracteristica de mediu	Chemical pollution resistance class 3C3 conformitate cu EN/IEC 60721-3-3 Dust pollution resistance class 3S3 conformitate cu EN/IEC 60721-3-3
standarde	EN/IEC 61800-3 UL 508C EN/IEC 61800-5-1 IEC 61000-3-12 IEC 60721-3 IEC 61508 IEC 13849-1 EN/IEC 61800-3 (environment 1 category C2) EN/IEC 61800-3 (environment 2 category C3)
certificari produs	CSA TÜV UL REACH
marcaj	CE

## Durabilitatea ofertei

Sustainable offer status	Green Premium product
RoHS	Compliant - since 1526 - Schneider Electric declaration of conformity
REACH	Referința nu conține SVHC peste prag
Profil de mediu pentru produs	Disponibil

## Dimensions

Views: Front - Left - Rear

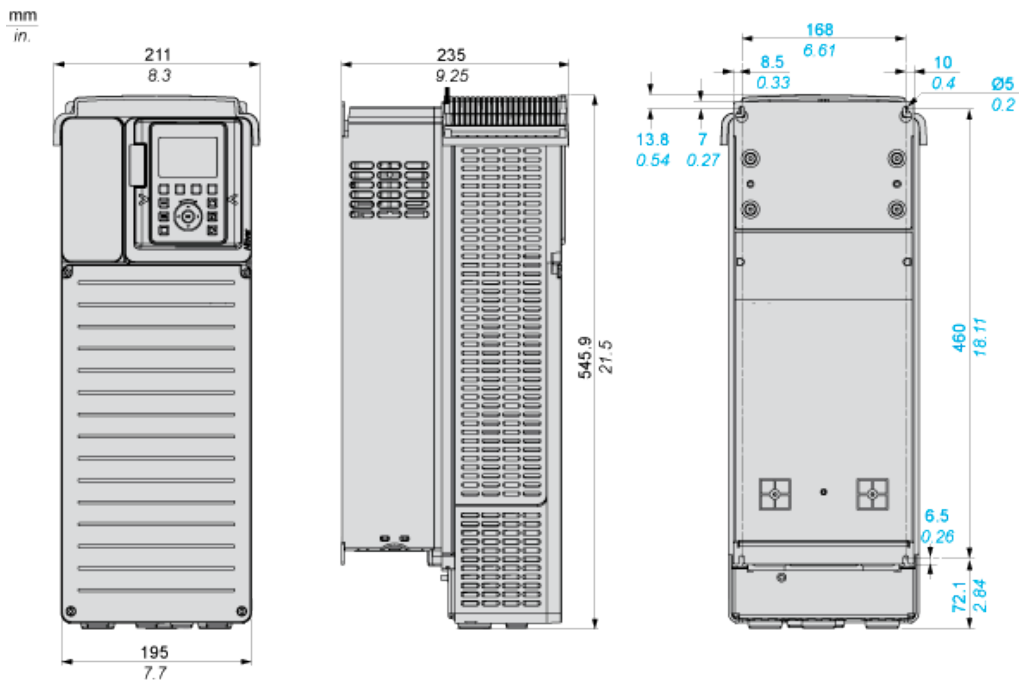

## Clearances

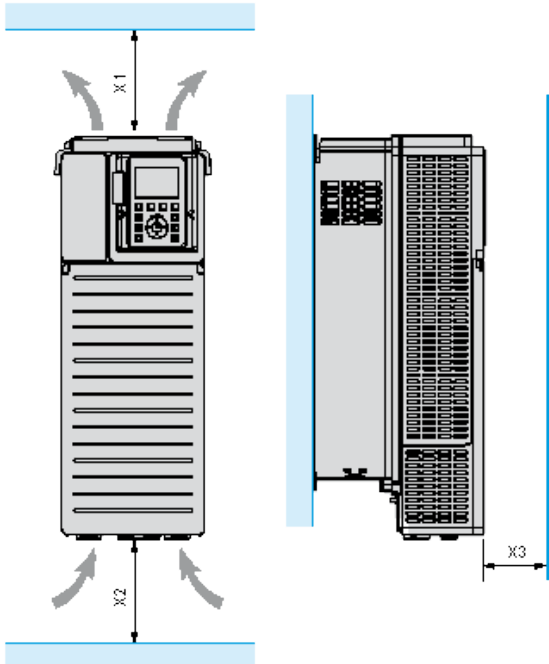

X1	X2	X3
≥ 100 mm (3.94 in.)	≥ 100 mm (3.94 in.)	≥ 10 mm (0.39 in.)

- Mount the device in a vertical position ( $\pm 10^\circ$ ). This is required for cooling the device.
- Do not mount the device close to heat sources.
- Leave sufficient free space so that the air required for cooling purposes can circulate from the bottom to the top of the drive.

## Mounting Types

### Mounting Type A: Individual IP21

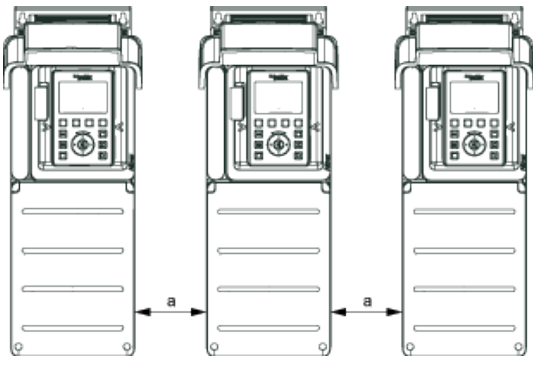

$a \geq 100 \text{ mm (3.94 in.)}$

**Mounting Type B: Side by Side IP20**

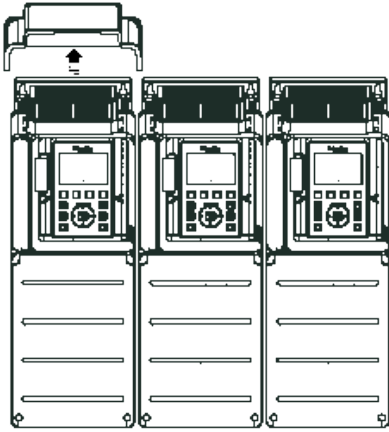

**Mounting Type C: Individual IP20**

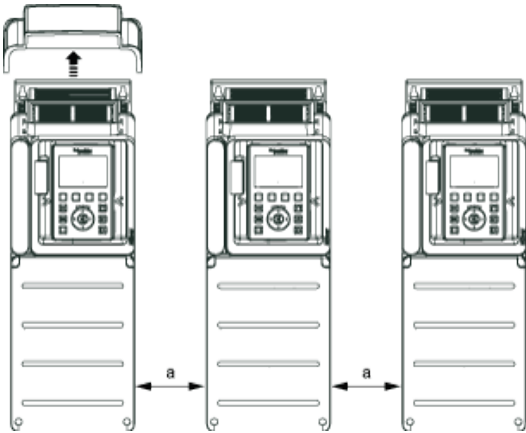

$a \geq 0$

**Single or Three-Phase Power Supply with Upstream Breaking via Line Contactor**

Connection diagrams conforming to standards EN 954-1 category 1 and IEC/EN 61508 capacity SIL1, stopping category 0 in accordance with standard IEC/EN 60204-1

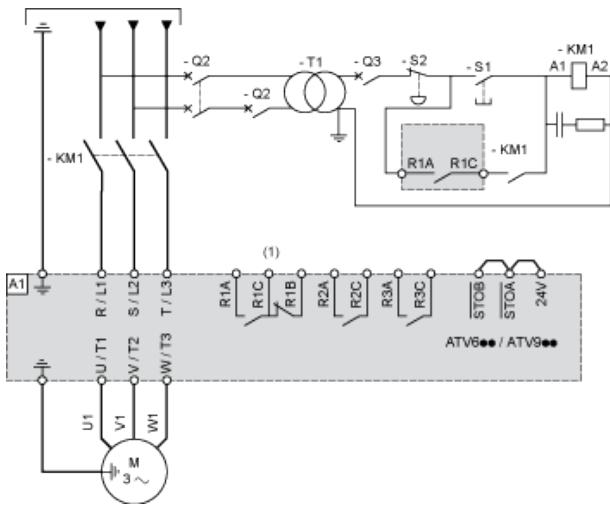

(1) Use digital output R1 set to operating state Fault to switch Off the product once an error is detected.

A1 : Drive

KM1 :Line Contactor

Q2, Circuit breakers

Q3 :

S1, Pushbuttons

S2 :

T1 : Transformer for control part

### Single or Three-Phase Power Supply with Downstream Breaking via Switch Disconnecter

Connection diagrams conforming to standards EN 954-1 category 1 and IEC/EN 61508 capacity SIL1, stopping category 0 in accordance with standard IEC/EN 60204-1

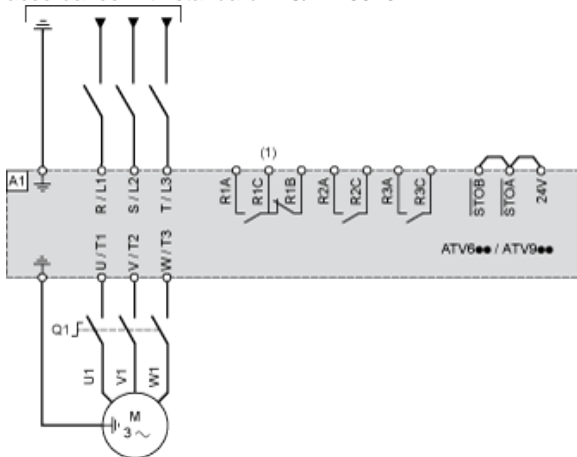

(1) Use digital output R1 set to operating state Fault to switch Off the product once an error is detected.

A1 : Drive

Q1 : Switch disconnector

### Control Block Wiring Diagram

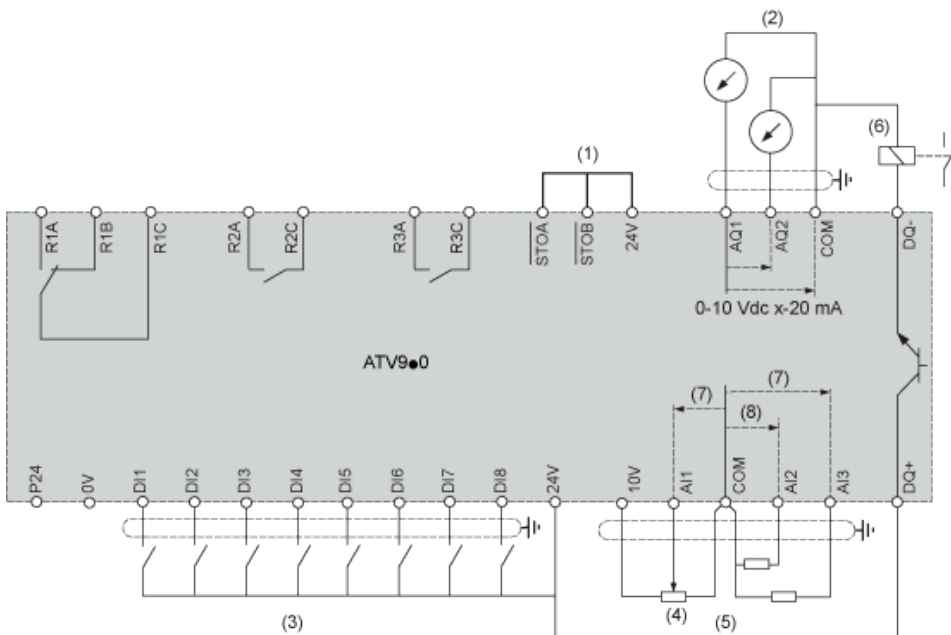

- (1) Safe Torque Off
- (2) Analog Output
- (3) Digital Input
- (4) Reference potentiometer
- (5) Analog Input
- (6) Digital Output
- (7) 0-10 Vdc, x-20 mA
- (8) 0-10 Vdc, -10 Vdc...+10 Vdc

R1A, Fault relay

R1B,

R1C :

R2A, Sequence relay

R2C :

R3A, Sequence relay

R3C :

### Sensor Connection

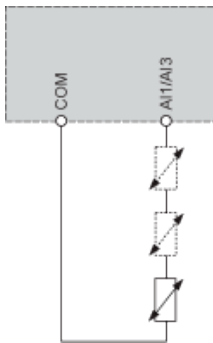

It is possible to connect either 1 or 3 sensors on terminals AI1 or AI3

### Derating Curves



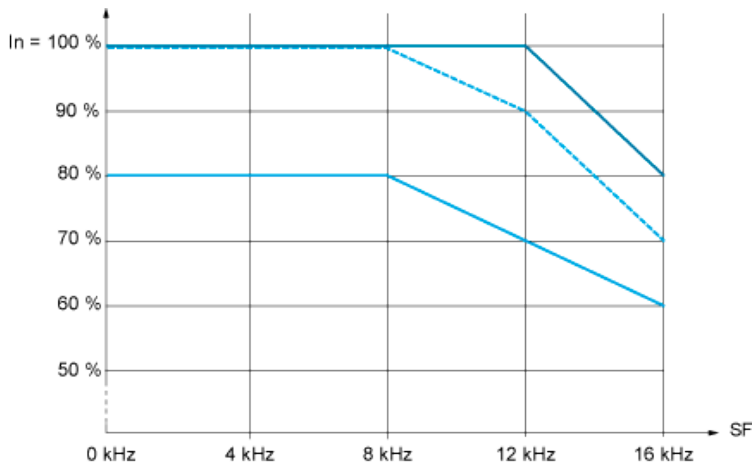

— 40 °C (104 °F) - Mounting type A, B and C

- - - 50 °C (122 °F) - Mounting type A, B and C

— 60 °C (140 °F) - Mounting type B and C

**In** : Nominal Drive Current

**SF** : Switching Frequency