

Limit switches

OsiSense XC Basic

Miniature design, plastic, type XCM N

1

■ XCM N
pre-cabled

□ With head for linear movement (plunger). Fixing by the body

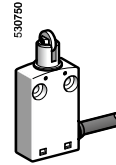
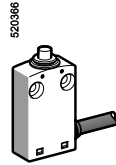

Page 1/28

□ With head for linear movement (plunger). Fixing by the head

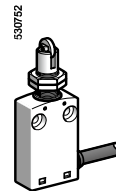

Page 1/28

□ With head for rotary movement (lever) or multi-directional

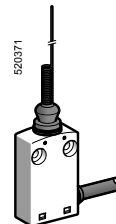
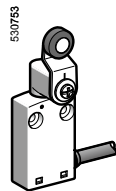

Page 1/28

Environment characteristics		
Conformity to standards	Products	IEC 60947-5-1, EN 60947-5-1, UL 508, CSA C22-2 n° 14
	Machine assemblies	IEC 60204-1, EN 60204-1
Product certifications		UL, CSA, CCC
Protective treatment	Standard version	"TC"
Ambient air temperature	For operation	- 25...+ 70°C
	For storage	- 40...+ 70°C
Vibration resistance	Conforming to IEC 60068-2-6	5 gn (10...500 Hz)
Shock resistance	Conforming to IEC 60068-2-27	25 gn (18 ms)
Electric shock protection		Class II conforming to IEC 61140 and NF C 20030
Degree of protection		IP 65 conforming to IEC 60529; IK 04 conforming to EN 50102
Materials	Bodies	Plastic
	Heads	Zamak
Contact block characteristics		
Rated operational characteristics		~ AC-15; B300 (Ue = 240 V, Ie = 1.5 A); Ithe = 6 A
		⋮ DC-13; R300 (Ue = 250 V, Ie = 0.1 A), conforming to IEC 60947-5-1 Appendix A, EN 60947-5-1
Rated insulation voltage		Ui = 400 V degree of pollution 3 conforming to IEC 60947-1 Ui = 300 V conforming to UL 508, CSA C22-2 n° 14
Rated impulse withstand voltage		U imp = 4 kV conforming to IEC 60947-1, IEC 60664
Short-circuit protection		6 A cartridge fuse type gG (gl)

Limit switches

OsiSense XC Basic

Miniature design, plastic, type XCM N

Pre-cabled

1

Type of head	Plunger (fixing by the body)				Plunger (fixing by the head)		
Type of operator	Metal end plunger	Steel roller plunger for lateral cam approach	Steel roller plunger for traverse cam approach	Thermoplastic roller lever plunger, horizontal actuation in 1 direction	M12 with metal end plunger	M12 with steel roller plunger for lateral cam approach	M12 with steel roller plunger for traverse cam approach

References	XCM N2110L1	XCM N2102L1	XCM N2103L1	XCM N2121L1	XCM N21F0L1	XCM N21F2L1	XCM N21F3L1
<p>2-pole NC + NO snap action</p>	<p>1.8 4.2(P) 5mm 0.8</p>	<p>3.1(A) 7(P) 1.4</p>	<p>3.1(A) 7(P) 1.4</p>	<p>65(A) 14(P) 2.8</p>	<p>1.8 4.2(P) 5mm 0.8</p>	<p>3.1(A) 7(P) 1.4</p>	<p>3.1(A) 7(P) 1.4</p>
Weight (kg)	0.080	0.080	0.080	0.090	0.065	0.095	0.095
Contact operation	closed open		(A) = cam displacement (P) = positive opening point		NC contact with positive opening operation		

Characteristics	Plunger (fixing by the body)			Plunger (fixing by the head)		
Switch actuation	On end	By 30° cam		On end	By 30° cam	
Type of actuation						
Maximum actuation speed	0.5 m/s	0.1 m/s		0.5 m/s	0.1 m/s	
Mechanical durability	5 million operating cycles					
Minimum force or torque	For tripping	8.5 N	7 N	2.5 N	8.5 N	7 N
	For positive opening	42.5 N	35 N	12.5 N	42.5 N	35 N
Cabling	PvR cable, 4 x 0.75 mm ² , length 1 metre					

Dimensions

<p>XCM N2110L1</p>	<p>XCM N2102L1, XCM N2103L1</p>	<p>XCM N21F2L1, XCM N21F3L1</p>
<p>XCM N2121L1</p>	<p>XCM N21F0L1</p>	<p>(1) 2 fixing holes Ø 4.2 mm, counterbored Ø 8 mm by 4 mm deep. (2) External diameter 7.5 mm. e: 8 mm max, panel cut-out Ø 12.5 mm. Fixing nut thickness 3.5 mm.</p>





Limit switches

OsiSense XC Basic

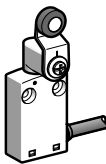
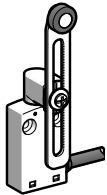
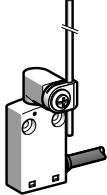
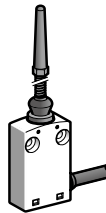
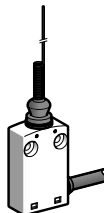
Miniature design, plastic, type XCM N

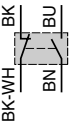
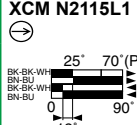
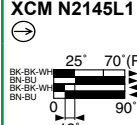
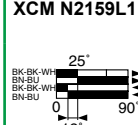
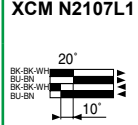
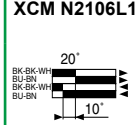
Pre-cabled

Type of head	Rotary (fixing by the body)			Multi-directional	
					
Type of operator	Thermoplastic roller lever	Variable length thermoplastic roller lever	Round thermoplastic rod lever, Ø 6 mm (1)	Spring lever with thermoplastic end (1)	"Cat's whisker" (1)

References	2-pole NC + NO snap action				
	XCM N2115L1 	XCM N2145L1 	XCM N2159L1 	XCM N2107L1 	XCM N2106L1 
Weight (kg)	0.100	0.105	0.080	0.085	0.080
Contact operation	 closed  open		(A) = cam displacement (P) = positive opening point	 NC contact with positive opening operation	
	(1) Value taken with actuation by moving part at 100 mm from the fixing.				

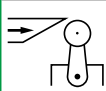
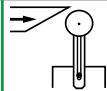
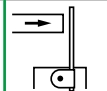
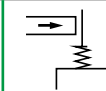
Characteristics	By 30° cam		By any moving part	
Switch actuation	By 30° cam		By any moving part	
Type of actuation				
Maximum actuation speed	1.5 m/s		1 m/s	1 m/s (any direction)
Mechanical durability	5 million operating cycles			
Minimum force or torque	For tripping: 0.1 N.m For positive opening: 0.5 N.m		-	-
Cabling	PvR cable, 4 x 0.75 mm ² , length 1 metre			

Dimensions

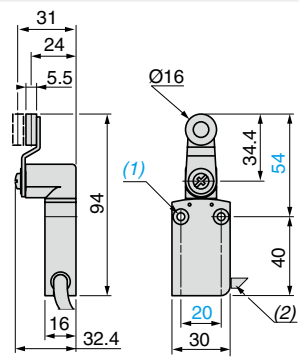
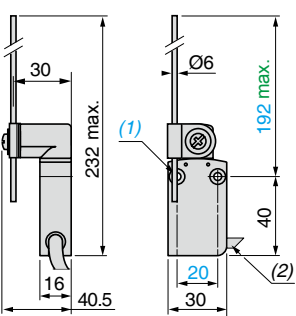
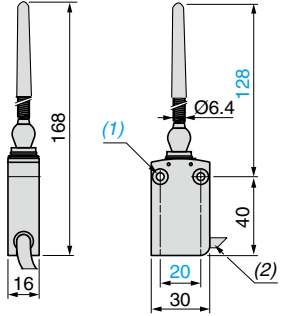
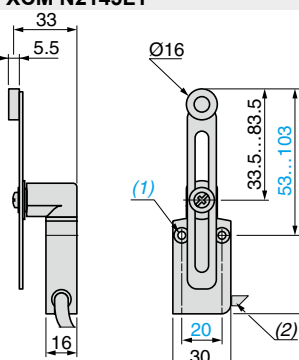
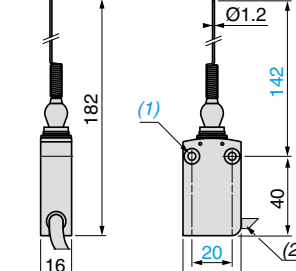
XCM N2115L1	XCM N2159L1	XCM N2107L1
		
XCM N2145L1	XCM N2106L1	
		

(1) 2 fixing holes Ø 4.2 mm, counterbored Ø 8 mm by 4 mm deep.
(2) External diameter 7.5 mm.